

CRNOGORSKA AKADEMIJA NAUKA I UMJETNOSTI
GLASNIK ODJELJENJA PRIRODNIH NAUKA, 16, 2005.

QERNOGORSKAYA AKADEMIYA NAUK I ISSKUSTV
GLASNIK OTDELENIYA ESTESTVENNYH NAUK, 16, 2005.

THE MONTENEGRIN ACADEMY OF SCIENCES AND ARTS
PROCEEDINGS OF THE SECTION OF NATURAL SCIENCES, 16, 2005

UDK 539.319

*Vlado A. Lubarda**

MOHR'S CIRCLES FOR NON-SYMMETRIC STRESSES AND COUPLE STRESSES

A b s t r a c t

Determination of the principal values of a non-symmetric stress tensor in plane strain problems of couple stress theory based on Mohr's circle construction is presented. It is shown that the antisymmetric component of the stress tensor affects the maximum shear stress, but not the maximum normal stress. The analysis is then extended to non-symmetric couple stresses under conditions of anti-plane strain.

MOHROVI KRUGOVI ZA NESIMETRIČNE NAPONE I NAPONSKE SPREGOVE

I z v o d

U radu je prezentovana procedura za odredjivanje glavnih napona nesimetričnog tenzora napona u ravnom problemu deformacije na bazi

*Prof. dr V.A. Lubarda, The Montenegrin Academy of Sciences and Arts, 81000 Podgorica, SCG, and University of California, San Diego, CA 92093-0411, USA.

konstrukcije Mohrovog kruga. Pokazano je da antisimetrična komponenta tenzora napona utiče na maksimalni smičući napon, ali ne i na maksimalni normalni napon. Analiza je proširena na slučaj nesimetričnih naponskih spregova u uslovima antiravne deformacije.

1. INTRODUCTION

In a micropolar continuum the deformation is described by the displacement vector and an independent rotation vector (Eringen, 1968,1999; Nowacki, 1986). In the couple stress theory, the rotation vector φ_i is not independent of the displacement vector u_i but subject to the constraint

$$\varphi_i = \frac{1}{2} e_{ijk} \omega_{jk} = \frac{1}{2} e_{ijk} u_{k,j}, \quad \omega_{ij} = e_{ijk} \varphi_k, \quad (1.1)$$

as in classical continuum mechanics (Mindlin and Tiersten, 1962; Koiter, 1964). The skew-symmetric alternating tensor is e_{ijk} , and ω_{ij} are the rectangular components of the infinitesimal rotation tensor. The comma designates the partial differentiation with respect to Cartesian coordinates x_i . The gradient of the rotation is a non-symmetric curvature tensor

$$\kappa_{ij} = \varphi_{j,i} = -e_{jkl} \epsilon_{ik,l}. \quad (1.2)$$

Since ϵ_{ij} is symmetric and e_{ijk} is skew-symmetric, the curvature tensor in couple stress theory is a deviatoric tensor ($\kappa_{kk} = 0$). A surface element dS transmits a force vector $T_i dS$ and a couple vector $M_i dS$. The surface forces are in equilibrium with a non-symmetric Cauchy stress t_{ij} , and the surface couples are in equilibrium with a non-symmetric couple stress m_{ij} , such that

$$T_i = n_j t_{ji}, \quad M_i = n_j m_{ji}, \quad (1.3)$$

where n_j are the components of the unit vector orthogonal to the surface element under consideration. In the absence of body forces and body couples, the differential equations of equilibrium are

$$t_{ji,j} = 0, \quad m_{ji,j} + e_{ijk} t_{jk} = 0. \quad (1.4)$$

By decomposing the stress tensor into its symmetric and antisymmetric part $t_{ij} = \sigma_{ij} + \tau_{ij}$, it readily follows from the moment equilibrium equation that

$$\tau_{ij} = -\frac{1}{2}e_{ijk}m_{lk,l}. \quad (1.5)$$

If the gradient of the couple stress vanishes at some point, the stress tensor is symmetric at that point.

The normal stress in the plane orthogonal to the direction \mathbf{n} is

$$t_n = \sigma_n = \sigma_{ij}n_in_j, \quad (1.6)$$

because $\tau_{ij}n_in_j = 0$ in view of the symmetry of n_in_j . Thus, the principal stresses of the symmetric tensor σ_{ij} are also the principal stresses of the nonsymmetric tensor t_{ij} , although there are shear stresses in the principal planes of t_{ij} due to antisymmetric shear stress components τ_{ij} (Lubarda, 2003). The magnitude of this shear stress is

$$\tau_n^2 = n_in_j\tau_{ik}\tau_{jk} = \tau_{12}^2 + \tau_{23}^2 + \tau_{31}^2 - (n_1\tau_{23} + n_2\tau_{31} + n_3\tau_{12})^2. \quad (1.7)$$

Similarly, the couple stress component $m_n = m_{ij}n_in_j$ is independent of the antisymmetric part of m_{ij} .

In the case of isotropic linear elasticity,

$$\sigma_{ij} = 2\mu\epsilon_{ij} + \lambda\epsilon_{kk}\delta_{ij}, \quad (1.8)$$

$$m_{ij} = 4\alpha\kappa_{ij} + 4\beta\kappa_{ji}. \quad (1.9)$$

where μ , λ , α , and β are the Lamé-type constants of couple stress elasticity. In this case, since $\kappa_{kk} = 0$, the couple stress is a deviatoric tensor ($m_{kk} = 0$).

2. MOHR'S CIRCLE FOR NON-SYMMETRIC STRESSES IN PLANE STRAIN

For the plane strain problems, the displacement components are $u_1 = u_1(x_1, x_2)$, $u_2 = u_2(x_1, x_2)$, and $u_3 = 0$. The stress and couple

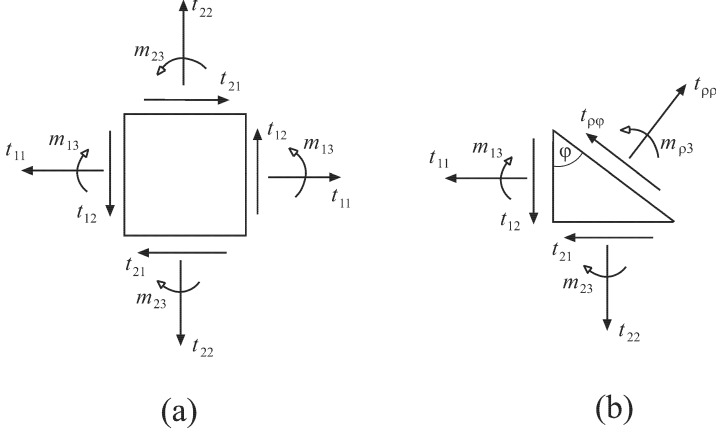

Figure 1: (a) A rectangular material element under conditions of plane strain; (b) an inclined plane at an angle φ supports the stresses $t_{\rho\rho}$ and $t_{\rho\varphi}$, and the couple stress $m_{\rho 3}$.

stress tensors are accordingly

$$\mathbf{t} = \begin{bmatrix} t_{11} & t_{12} & 0 \\ t_{21} & t_{22} & 0 \\ 0 & 0 & t_{33} \end{bmatrix}, \quad \mathbf{m} = \begin{bmatrix} 0 & 0 & m_{13} \\ 0 & 0 & m_{23} \\ m_{31} & m_{32} & 0 \end{bmatrix}. \quad (2.1)$$

Consider a material element with sides parallel to coordinates directions x_1 and x_2 (Fig. 1a). In an inclined plane whose normal ρ makes an angle φ with the direction x_1 , the normal and shear stresses are $t_{\rho\rho}$ and $t_{\rho\varphi}$, and the couple stress is $m_{\rho 3}$ (Fig. 1b). From the equilibrium conditions of the triangular element it readily follows that

$$m_{\rho 3} = m_{13} \cos \varphi + m_{23} \sin \varphi, \quad (2.2)$$

$$t_{\rho\rho} = \frac{1}{2} (t_{11} + t_{22}) + \frac{1}{2} (t_{11} - t_{22}) \cos 2\varphi + \frac{1}{2} (t_{12} + t_{21}) \sin 2\varphi, \quad (2.3)$$

$$t_{\rho\varphi} = \frac{1}{2} (t_{12} - t_{21}) + \frac{1}{2} (t_{12} + t_{21}) \cos 2\varphi - \frac{1}{2} (t_{11} - t_{22}) \sin 2\varphi. \quad (2.4)$$

The planes with the maximum magnitude of $t_{\rho\rho}$ and $t_{\rho\varphi}$ are defined

by

$$\tan 2\varphi_1 = \frac{t_{12} + t_{21}}{2t_{11}}, \quad \tan 2\varphi_2 = -\frac{2t_{11}}{t_{12} + t_{21}}, \quad (2.5)$$

with the obvious connection $\varphi_2 = \varphi_1 \pm \pi/4$. The corresponding extreme values of the stresses are

$$t_{\rho\rho}^{\max} = \frac{1}{2}(t_{11} + t_{22}) \pm \frac{1}{2}[(t_{11} - t_{22})^2 + (t_{12} + t_{21})^2]^{1/2}, \quad (2.6)$$

$$t_{\rho\varphi}^{\max} = \frac{1}{2}(t_{12} - t_{21}) \pm \frac{1}{2}[(t_{11} - t_{22})^2 + (t_{12} + t_{21})^2]^{1/2}. \quad (2.7)$$

It is noted that $t_{\rho\rho}^{\max}$ depends only on the symmetric part of the stress tensor t_{ij} . Indeed, if we decompose \mathbf{t} into its symmetric and antisymmetric parts,

$$\boldsymbol{\sigma} = \begin{bmatrix} \sigma_{11} & \sigma_{12} & 0 \\ \sigma_{12} & \sigma_{22} & 0 \\ 0 & 0 & \sigma_{33} \end{bmatrix}, \quad \boldsymbol{\tau} = \begin{bmatrix} 0 & \tau_{12} & 0 \\ -\tau_{12} & 0 & 0 \\ 0 & 0 & 0 \end{bmatrix}, \quad (2.8)$$

where $\sigma_{11} = t_{11}$, $\sigma_{22} = t_{22}$, $\sigma_{33} = t_{33}$, and

$$\sigma_{12} = \frac{1}{2}(t_{12} + t_{21}), \quad \tau_{12} = \frac{1}{2}(t_{12} - t_{21}), \quad (2.9)$$

we can write

$$t_{\rho\rho}^{\max} = \sigma_{\rho\rho}^{\max} = \frac{1}{2}(\sigma_{11} + \sigma_{22}) \pm \frac{1}{2}[(\sigma_{11} - \sigma_{22})^2 + 4\sigma_{12}^2]^{1/2}, \quad (2.10)$$

$$t_{\rho\varphi}^{\max} = \tau_{12} \pm \sigma_{\rho\varphi}^{\max}, \quad \sigma_{\rho\varphi}^{\max} = \frac{1}{2}[(\sigma_{11} - \sigma_{22})^2 + 4\sigma_{12}^2]^{1/2}. \quad (2.11)$$

The physical interpretation of Eq. (2.11) is facilitated by observing that the shear stress on any inclined plane due to antisymmetric stress component τ_{12} is also equal to τ_{12} . This follows from the force equilibrium condition for the triangular element shown in Fig. 2b. The moment equilibrium is ensured by the non-uniform field of couple stresses (not shown in Fig. 2).

Equations (2.3) and (2.4) can be combined to give

$$\begin{aligned} \left[t_{\rho\rho} - \frac{1}{2}(t_{11} + t_{22}) \right]^2 + \left[t_{\rho\varphi} - \frac{1}{2}(t_{12} - t_{21}) \right]^2 \\ = \frac{1}{4}[(t_{11} - t_{22})^2 + (t_{12} + t_{21})^2], \end{aligned} \quad (2.12)$$

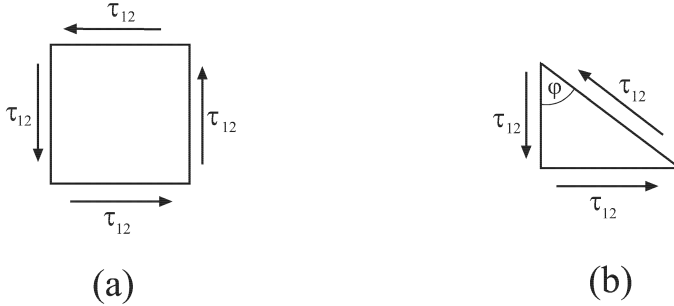

Figure 2: (a) A rectangular material element carrying the antisymmetric shear stress τ_{12} ; (b) the corresponding shear stress at an arbitrarily inclined plane is also τ_{12} .

which defines Mohr's circle for the non-symmetric stress components under conditions of plane strain (Fig. 3). The normal stress $t_{\rho\rho} = (t_{11} + t_{22})/2$ acts in the planes where $t_{\rho\varphi}$ attains its maximum or minimum value, while the shear stress $t_{\rho\varphi} = (t_{12} - t_{21})/2$ acts in the planes where $t_{\rho\rho}$ has its maximum or minimum value. If $t_{12} = t_{21}$, Eq. (2.12) defines the classical Mohr's circle for a symmetric stress tensor (Timoshenko and Goodier, 1970).

2.1. Eigenvalue Analysis

The extreme values of the stresses $t_{\rho\rho}$ and $t_{\rho\varphi}$ can also be determined by an eigenvalue analysis. If $\mathbf{n} = \{n_1, n_2\}$ is the unit vector perpendicular to the plane which supports $t_{\rho\rho}$ and $t_{\rho\varphi} = (t_{12} - t_{21})/2$, we can write

$$n_j t_{ji} = \lambda n_i + \frac{1}{2} (t_{12} - t_{21}) \hat{n}_i, \quad (i, j = 1, 2). \quad (2.13)$$

The unit vector orthogonal to \mathbf{n} is $\hat{\mathbf{n}} = \{-n_2, n_1\}$. The system of

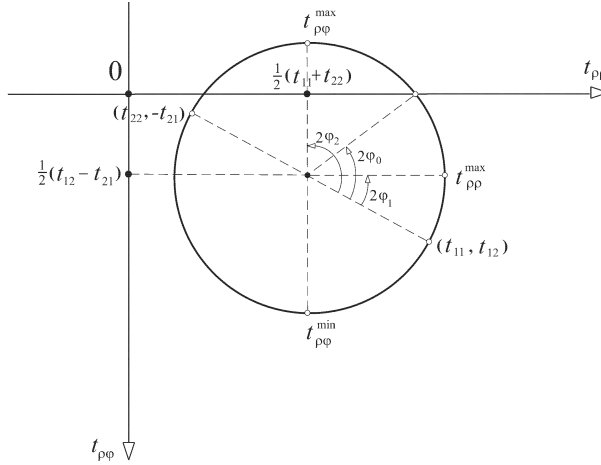

Figure 3: Mohr's circle for non-symmetric stresses in plane strain. The center of the circle is at the point with the coordinates $\frac{1}{2}[(t_{11} + t_{22}), (t_{12} - t_{21})]$. The radius of the circle is $\frac{1}{2}[(t_{11} - t_{22})^2 + (t_{12} + t_{21})^2]^{1/2}$. The angles φ_1 , φ_2 , and φ_0 specify the planes of $t_{\rho\rho}^{\max}$, $t_{\rho\varphi}^{\max}$, and $t_{\rho\varphi} = 0$.

equations (2.13) has a nontrivial solution for (n_1, n_2) if λ is given by the right-hand side of Eq. (2.6). The corresponding planes are defined by

$$\tan \varphi_1 = -\frac{t_{11} - t_{22}}{t_{12} + t_{21}} \pm \left[1 + \left(\frac{t_{11} - t_{22}}{t_{12} + t_{21}} \right)^2 \right]^{1/2}, \quad (2.14)$$

in agreement with the first expression from Eq. (2.5).

Similarly, for the plane which supports the stresses $t_{\rho\varphi}$ and $t_{\rho\rho} = (t_{11} + t_{22})/2$, we have

$$n_j t_{ji} = \lambda \hat{n}_i + \frac{1}{2} (t_{11} + t_{22}) n_i, \quad (i, j = 1, 2). \quad (2.15)$$

The system of equations (2.15) has a nontrivial solution for (n_1, n_2) if λ is given by the right-hand side of Eq. (2.7). The corresponding

planes are defined by

$$\tan \varphi_2 = \frac{t_{12} + t_{21}}{t_{11} - t_{22}} \pm \left[1 + \left(\frac{t_{12} + t_{21}}{t_{11} - t_{22}} \right)^2 \right]^{1/2}, \quad (2.16)$$

in agreement with the second expression from Eq. (2.5).

The planes with the vanishing $t_{\rho\varphi}$ (if they exist) are found by solving the eigenvalue problem

$$n_j t_{ji} = \lambda n_i, \quad (2.17)$$

which specifies

$$\lambda = t_{\rho\rho} = \frac{1}{2}(t_{11} + t_{22}) \pm \frac{1}{2} [(t_{11} - t_{22})^2 + 4t_{12}t_{21}]^{1/2}. \quad (2.18)$$

The corresponding planes are defined by

$$\tan \varphi_0 = \frac{1}{2t_{21}} \left\{ -(t_{11} - t_{22}) \pm [(t_{11} - t_{22})^2 + 4t_{12}t_{21}]^{1/2} \right\}. \quad (2.19)$$

There is one such plane if $(t_{11} - t_{22})^2 = -4t_{12}t_{21}$, and two such planes if $(t_{11} - t_{22})^2 > -4t_{12}t_{21}$.

The planes with the vanishing $t_{\rho\rho}$ (if they exist) are found by solving the eigenvalue problem

$$n_j t_{ji} = \lambda \hat{n}_i, \quad (2.20)$$

which specifies

$$\lambda = t_{\rho\varphi} = \frac{1}{2}(t_{12} - t_{21}) \pm \frac{1}{2} [(t_{12} + t_{21})^2 - 4t_{11}t_{22}]^{1/2}. \quad (2.21)$$

The corresponding planes are defined by

$$\tan \bar{\varphi}_0 = \frac{1}{2t_{22}} \left\{ -(t_{12} + t_{21}) \pm [(t_{12} + t_{21})^2 - 4t_{11}t_{22}]^{1/2} \right\}, \quad (2.22)$$

provided that $(t_{12} + t_{21})^2 \geq 4t_{11}t_{22}$.

3. MOHR'S CIRCLE FOR COUPLE STRESSES IN ANTI-PLANE STRAIN

For the anti-plane strain problems, the displacement components are $u_1 = u_2 = 0$, and $u_3 = u_3(x_1, x_2)$. The stress and couple stress tensors have the components

$$\mathbf{t} = \begin{bmatrix} 0 & 0 & t_{13} \\ 0 & 0 & t_{23} \\ t_{31} & t_{32} & 0 \end{bmatrix}, \quad \mathbf{m} = \begin{bmatrix} m_{11} & m_{12} & 0 \\ m_{21} & m_{22} & 0 \\ 0 & 0 & 0 \end{bmatrix}. \quad (3.1)$$

A material element under conditions of anti-plane strain is shown in Fig. 4a. In an inclined plane whose normal ρ makes an angle φ with the longitudinal direction x_1 , the shear stress is $t_{\rho 3}$ and the couple stresses are $m_{\rho\rho}$ and $m_{\rho\varphi}$ (Fig. 4b). From the equilibrium conditions of the triangular element it readily follows that

$$t_{\rho 3} = t_{13} \cos \varphi + t_{23} \sin \varphi, \quad (3.2)$$

$$m_{\rho\rho} = \frac{1}{2} (m_{11} + m_{22}) + \frac{1}{2} (m_{11} - m_{22}) \cos 2\varphi + \frac{1}{2} (m_{12} + m_{21}) \sin 2\varphi, \quad (3.3)$$

$$m_{\rho\varphi} = \frac{1}{2} (m_{12} - m_{21}) + \frac{1}{2} (m_{12} + m_{21}) \cos 2\varphi - \frac{1}{2} (m_{11} - m_{22}) \sin 2\varphi. \quad (3.4)$$

The planes with the maximum magnitude of $m_{\rho\rho}$ and $m_{\rho\varphi}$ are defined by

$$\tan 2\varphi_1 = \frac{m_{12} + m_{21}}{2m_{11}}, \quad \tan 2\varphi_2 = -\frac{2m_{11}}{m_{12} + m_{21}}. \quad (3.5)$$

The two angles are related by $\varphi_2 = \varphi_1 \pm \pi/4$. The corresponding extreme values of the couple stress components are

$$m_{\rho\rho}^{\max} = \frac{1}{2} (m_{11} + m_{22}) \pm \frac{1}{2} [(m_{11} - m_{22})^2 + (m_{12} + m_{21})^2]^{1/2}, \quad (3.6)$$

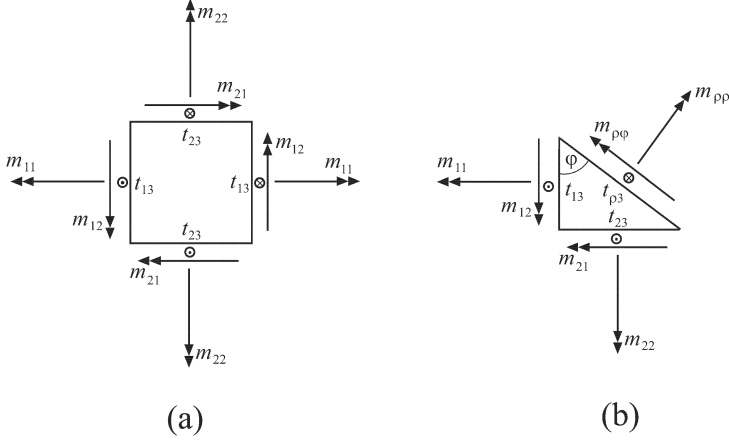

Figure 4: (a) A rectangular material element under conditions of anti-plane strain; (b) an inclined plane at an angle φ supports the shear stress $t_{\rho 3}$ and couple stresses $m_{\rho\rho}$ and $m_{\rho\varphi}$.

$$m_{\rho\varphi}^{\max} = \frac{1}{2} (m_{12} - m_{21}) \pm \frac{1}{2} [(m_{11} - m_{22})^2 + (m_{12} + m_{21})^2]^{1/2}. \quad (3.7)$$

Again, it may be noted that $m_{\rho\rho}^{\max}$ does not depend on the anti-symmetric part of the couple stress tensor, i.e., on the component $(m_{12} - m_{21})/2$.

Equations (3.3) and (3.4) can be combined to give

$$\begin{aligned} \left[m_{\rho\rho} - \frac{1}{2} (m_{11} + m_{22}) \right]^2 + \left[m_{\rho\varphi} - \frac{1}{2} (m_{12} - m_{21}) \right]^2 \\ = \frac{1}{4} [(m_{11} - m_{22})^2 + (m_{12} + m_{21})^2]. \end{aligned} \quad (3.8)$$

This defines Mohr's circle for the couple stresses in anti-plane strain (Fig. 5). The couple stress component $m_{\rho\rho} = (m_{11} + m_{22})/2$ acts in the planes where $m_{\rho\varphi}$ attains its maximum or minimum value, while $m_{\rho\varphi} = (m_{12} - m_{21})/2$ acts in the planes where $m_{\rho\rho}$ has its maximum

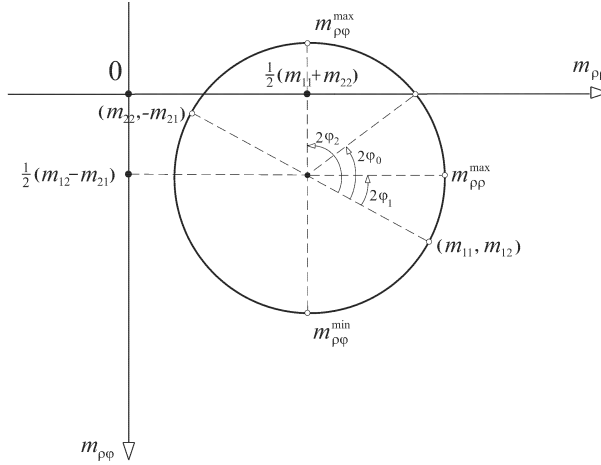

Figure 5: Mohr's circle for couple stresses in anti-plane strain. The center of the circle is at the point with the coordinates $\frac{1}{2}[(m_{11} + m_{22}), (m_{12} - m_{21})]$. The radius of the circle is $\frac{1}{2}[(m_{11} - m_{22})^2 + (m_{12} + m_{21})^2]^{1/2}$. The angles φ_1 , φ_2 , and φ_0 specify the planes of $m_{\rho\rho}^{\max}$, $m_{\rho\phi}^{\max}$, and $m_{\rho\phi} = 0$.

or minimum value.

The planes for which $m_{\rho\phi} = 0$ are defined by

$$\tan \varphi_0 = \frac{1}{2m_{21}} \left\{ -(m_{11} - m_{22}) \pm [(m_{11} - m_{22})^2 + 4m_{12}m_{21}]^{1/2} \right\}. \quad (3.9)$$

There is one such plane if $(m_{11} - m_{22})^2 = -4m_{12}m_{21}$, and two such planes if $(m_{11} - m_{22})^2 > -4m_{12}m_{21}$. The normal component of the couple stress in these planes is

$$m_{\rho\rho} = \frac{1}{2}(m_{11} + m_{22}) \pm \frac{1}{2} [(m_{11} - m_{22})^2 + 4m_{12}m_{21}]^{1/2}. \quad (3.10)$$

The planes for which $m_{\rho\rho} = 0$ are defined by

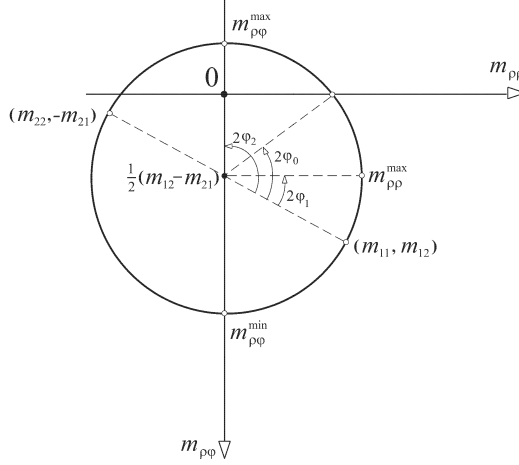

Figure 6: Mohr's circle for couple stresses in anti-plane strain in the case when the couple stress is a deviatoric tensor. The center of the circle is along the $m_{\rho\varphi}$ axis at the distance $\frac{1}{2}(m_{12} - m_{21})$ from the origin. The radius of the circle is $m_{\rho\rho}^{\max} = [m_{11}^2 + \frac{1}{4}(m_{12} + m_{21})^2]^{1/2}$.

$$\tan \bar{\varphi}_0 = \frac{1}{2m_{22}} \left\{ -(m_{12} + m_{21}) \pm [(m_{12} + m_{21})^2 - 4m_{11}m_{22}]^{1/2} \right\}, \quad (3.11)$$

provided that $(m_{12} + m_{21})^2 \geq 4m_{11}m_{22}$. The non-vanishing couple stress in these planes is

$$m_{\rho\varphi} = \frac{1}{2}(m_{12} - m_{21}) \pm \frac{1}{2} [(m_{12} + m_{21})^2 - 4m_{11}m_{22}]^{1/2}. \quad (3.12)$$

The extreme values of the couple stresses $m_{\rho\rho}$ and $m_{\rho\varphi}$ can also be determined by an eigenvalue analysis. The derivation is analogous to that presented in section 2. The resulting formulas can be obtained from Eqs. (2.13)–(2.22) by replacing the stress symbol t with the couple stress symbol m . In the case when the couple stress is a deviatoric tensor (e.g., isotropic linear elasticity), the results simplify due to the

condition $m_{11} + m_{22} = 0$. The corresponding Mohr's circle is shown in Fig. 6.

Acknowledgment

The research support from the Montenegrin Academy of Sciences and Arts is kindly acknowledged.

REFERENCES

- Eringen, A.C. (1968) Theory of micropolar elasticity. In *Fracture – An Advanced Treatise* (Ed. H. Liebowitz), pp. 621–729. Academic Press, New York.
- Eringen, A.C. (1999) *Microcontinuum Field Theories*, Springer-Verlag, New York.
- Koiter, W.T. (1964) Couple-stresses in the theory of elasticity. *Proc. Ned. Akad. Wet. (B)* **67**, Part I: 17–29, Part II: 30–44.
- Lubarda, V.A. (2003) Circular inclusions in anti-plane strain couple stress elasticity. *Int. J. Solids Struct.* **40**, 3827–3851.
- Mindlin, R.D. and Tiersten, H.F. (1962) Effects of couple-stresses in linear elasticity. *Arch. Ration. Mech. Anal.* **11**, 415–448.
- Nowacki, W. (1986) *Theory of Asymmetric Elasticity*, (translated by H. Zorski). Pergamon Press, Oxford, and PWN - Polish Sci. Publ., Warszawa.
- Timoshenko, S. and Goodier, J.N. (1970) *Theory of Elasticity*. McGraw Hill, New York.

